



Ages 14+
READ THE INSTRUCTION MANUAL CAREFULLY



THE HUBSAN X4 DESIRE

ITEM NO.: H502E

ARM/DISARM MOTORS, SEE PAGE 09

RTH FUNCTION, SEE PAGE 13

COMPASS CALIBRATION, SEE PAGE 17

TRANSMITTER CALIBRATION, SEE PAGE 19



COMPASS CALIBRATION BEFORE FLY

Compass calibration is required after the binding as instructed on the transmitter.

- 1.) Rotate the X4 horizontally until the "Set Compass 2" displays on the screen.
- 2.) Put the X4 nose down and rotate it vertically until the "Set Compass 2" disappears.
- 3.) Calibration done.

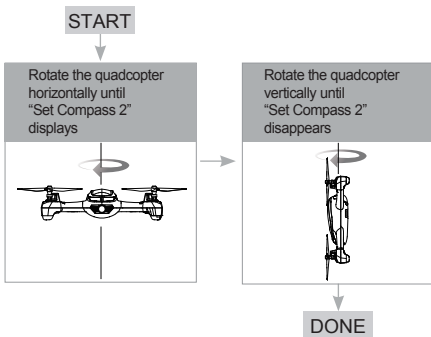

-
- ⊘ Do not calibrate the compass in a strong magnetic field
 - Do not carry ferromagnetic materials with you while calibrating the compass, such as keys, cell phones, etc.
-

Hubsan X4 Desire

Please read the instruction manual carefully!

IMPORTANT SAFETY NOTES

OPERATION:

Be extremely careful and responsible when using the drone. Small electronic components can be damaged by crashing or by dropping the X4 into water. To avoid further damages, please replace broken parts immediately.

Flight:

- Take responsibility for the safety of yourself and others when flying the X4!
- Do not fly the X4 in crowded places.
- Do not fly in bad weather.
- Never try to catch the X4 while it is in flight.
- This model is intended for experienced pilots age 14+.
- Power off the X4 after flight, to prevent the propellers from causing injuries.
- Always remove the battery after you stop flying to avoid injuries from accidentally powering on the motors.
- Always take great caution to protect yourself when near the propellers.
The flight system will start after powering on regardless of the transmitter signal. The high speed propellers are very dangerous.
- Power off the X4 after every flight or the propellers may still rotate and cause injury.





INTRODUCTION

Thank you for buying the HUBSAN product. It is designed as an easy-to-use, multi-functional RC model, capable of hovering and acrobatic flight maneuvers. Please read the manual carefully and follow all the instructions. Be sure to keep the manual for future reference.

Quadcopter Weight: 155g(including battery)

1. ITEMS INCLUDED IN THE BOX

Check all the items in the box before using.

S/N	Part Name	Photos	Q'ty	Remarks
1	Quad copter		1PC	Equipped with smart flight controller, GPS and compass
2	Propellers		8PCS	Propeller A 4pcs, Propeller B 4pcs
3	Transmitter		1PC	Transmitter (powered by 4 X AAA battery-Not included)
4	7.4V Li-Po battery		1PC	For quad copter
5	USB Charger		1PC	For Li-Po battery charging

6 Screw-driver



1PC

For removing
propellers

7 User Manual



1PC

Disclaimer
Hubsan X4
Instruction Manual

2. QUAD COPTER MOTOR LED INDICATOR

Indicator Status:

Front LED: is blue; Back LED: is red.

1. Power on: 4 LED indicators blink simultaneously every 1.5 seconds.
2. Compass Calibration:
 - 1). Horizontal calibration: 4 LED indicators blink circularly.
 - 2). Vertical calibration: 4 LED indicators blink alternately.
3. GPS Flight: 4 LED indicators remain lighted.
4. GPS Return : 2 front LED remain lighted, and 2 back LED blink twice every second.
5. Photo: 2 front LED remain lighted, 2 back LED blink once.
6. Video: 2 front LED remain lighted, 2 back LED blink alternately.
7. LED indicators can be turned off by pressing the Motor LED Switch on transmitter when taking pictures and videos.

3. QUAD COPTER BATTERY

3.1 INTRODUCTION

The quad copter battery is a rechargeable Li-Po battery with 610mAh capacity and 7.4V voltage.

The battery should only be charged with the HUBSAN charger to avoid overcharge.



Please make sure the battery is fully charged before first time use.

3.2 INSTALL THE BATTERY

Push the battery into the battery compartment correctly and connect the battery plugs with the correct polarity. Close the battery compartment cover.

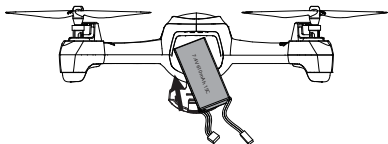

3.3 CHARGING

Connect the battery to the USB charger, then connect the USB charger to USB devices, such as a computer or mobile power charger.

It takes around 150 minutes to fully charge the battery with 460~495mA current. The USB LED indicator blink slowly in red when charging and will remain lighted when the battery is fully charged. Please unplug the charger and battery when the charging is completed.



Please fully charge the batteries to avoid loss of control due to low voltage.

Risk of explosion if battery is replaced by an incorrect type.
Dispose of used batteries according to the local regulations.

4. PROPELLER

Notice: Mind the differing colors of the A and B propeller screws!

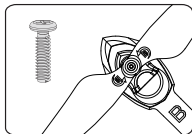

Propeller B — Silver screw

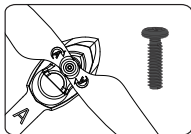

Propeller A — Black screw

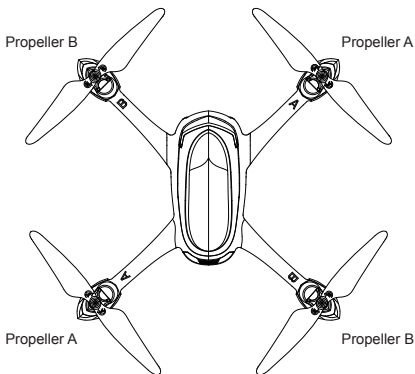

Removing Propellers

If the propeller needs changing, please use a screwdriver to untighten the screw clockwise on propeller A. To remove the screw on propeller B, untighten its screw counterclockwise.

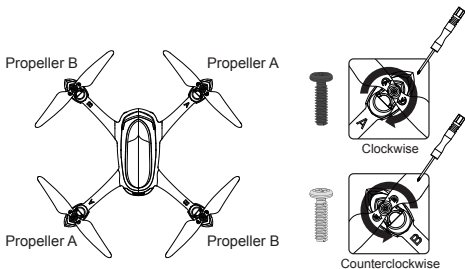

Installing Propellers

Use a screwdriver and gently tighten the screw counterclockwise for propeller A. Gently tighten the screw clockwise for propeller B.

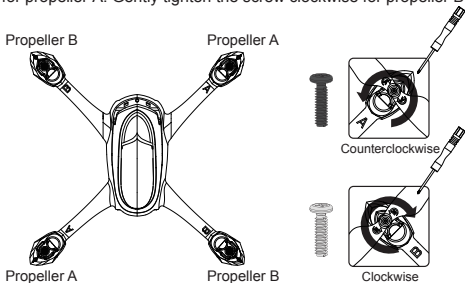

5. START TO FLY

5.1 FLIGHT ENVIRONMENT

- (1) The flying area should be open and without tall buildings or other obstacles; the steel structure within buildings interferes the compass and the GPS signal.
- (2) DO NOT fly in bad weather such as strong wind, heavy snow, rain or fog.
- (3) Keep away from barriers, people, power cables, trees, and other obstructions.
- (4) DO NOT fly near radio towers or airports.
- (5) The X4 control system will not work properly at the South or North Pole
- (6) DO NOT fly in restricted areas and obey your country's laws and regulations.



High Tension Line



Airport



Interference



Rain

5.2 BINDING

The binding is completed in factory.

For re-binding, press Photo/Video button and power on the transmitter simultaneously until "H" displayed, then power on the drone, and place it very close to the transmitter, the binding will be completed after one "beep" heard.

Should the binding failed, please power off the drone and repeat above steps.

5.3 ARM/ DISARM THE MOTORS

Arm the motors

Method : Pull the left stick to the left lowest corner and the right stick to the right lowest corner as the picture shows. Release both sticks after the motors are armed.



Disarm the motors



Method : Pull the left stick to the left lowest corner and the right stick to the right lowest corner again, and release both sticks after the motors are disarmed.



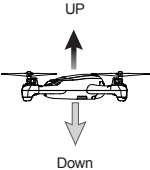

⊘ Do not stop the motors during the flight to avoid crashing.

💡 Push the sticks lightly. Release the sticks after the motors are armed or disarmed.

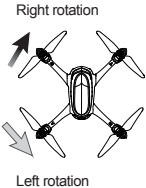
5.4 BASIC FLIGHT

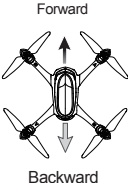
The operation mode for the transmitter including Mode 1 or Mode 2. The manual will use Mode 2 as an example to illustrate the transmitter's operation.

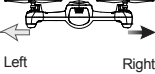
Transmitter (Model 2)	X4	Remarks
		<p>The throttle stick controls the ascent and descent .</p> <p>Push up the stick and the X4 will ascend.</p> <p>Pull down the stick and the X4 will descend.</p> <p>When the stick is in the center, the X4 will hover and hold its altitude automatically .</p> <p>Move the throttle stick above the center position to take off. (Move the stick slowly to prevent the X4 from ascending too quickly.)</p>
		<p>The Rudder stick controls the rotate direction .</p> <p>Push the stick left and the X4 will rotate counter-clockwise.</p> <p>Push the stick right and the X4 will rotate clockwise.</p> <p>When the stick is in the center, the X4 will keep the current direction and not rotate.</p> <p>Pushing harder will cause the X4 to rotate faster in the corresponding directions.</p>

		<p>The Elevator stick controls the X4 forward and backward.</p> <p>Push the stick up and the X4 will fly forward.</p> <p>Pull the stick down and the X4 will fly backward.</p> <p>When the stick is in the center, the X4 will hold its position.</p> <p>The angle of stick movement corresponds to the angle of tilt and flight speed.</p>
		<p>The Aileron stick controls the left and right flight.</p> <p>Push the stick left and the X4 will fly to the left.</p> <p>Push the stick right and the X4 will fly to the right.</p> <p>The X4 should be horizontal and keep the current status when the stick is in the center.</p> <p>The angle of stick movement corresponds to the angle of tilt and flight speed.</p>
 <p>GPS and RTH function only available outdoors.</p>	<p>RTH only available when there are no less than 6 GPS satellites displayed on transmitter. Press the RTH for 1.5 seconds to activate the function, press again to stop the RTH.</p>	

5.5 PHOTO / VIDEO

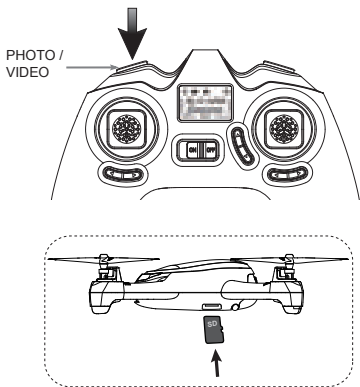

Insert the SD card into quadcopter before using Photo/Video function.
Press the Photo/Video button for 0.5 second to take photos.
Press the Photo/Video button for 1.5 seconds to take videos and press again to save the videos.

 Stop recording before the SD card is removed.

6. ADVANCED PERFORMANCE SETUP

6.1 GPS POSITIONING/ HOME POINT SETTING

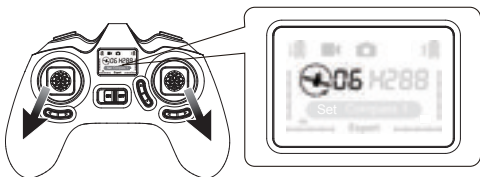



- 1.) GPS Positioning works ONLY when the GPS signal has no less than 6 satellites.
- 2.) Home Point is recorded when armed the motors with no less than 6 GPS satellites.
- 3.) You should be in an open place to search for the GPS satellites, it'll take 3 mins to finish the searching, and the GPS signal strength depends on the flying environment.

6.2 RTH MODE (RETURN TO HOME)

ENTER/ EXIT RTH MODE

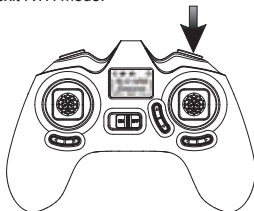
Press the RTH button for 1.5 seconds, and the drone will enter into RTH mode. The flight control system will control the drone to fly back to the home point and land automatically. Press the button again for 1.5 seconds to exit RTH mode.



 The RTH MODE only works when the GPS with no less than 6 satellites.

6.3 FAILSAFE MODE

The drone will enter into Failsafe Mode when the connection is lost from the transmitter. The flight control system will control the quad copter to return to the home point and land automatically. The Failsafe Mode helps to avoid further injuries or damages.

CONDITIONS WHICH ACTIVATE THE FAILSAFE MODE

- (1) Transmitter is powered off.
- (2) The flight distance is beyond the range of the transmitter's signal transmission.
- (3) The transmitter's signal was interrupted by some other strong electronic interference.

- ⊘ • To ensure that the X4 can return safely to its home point when GPS signal is lost, fly the X4 in safe flight area.
- If the quantity of GPS satellites drops below six for more than 20 seconds while the X4 is returning home, the X4 will descend automatically.
- The X4 will not avoid obstacles automatically while in failsafe mode.

7. TRANSMITTER

Interface

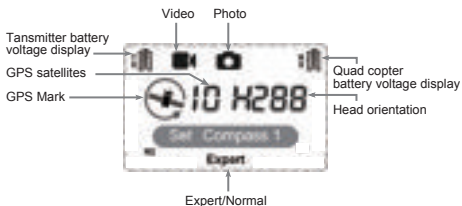

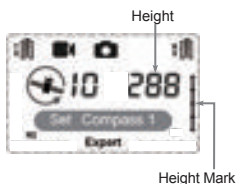
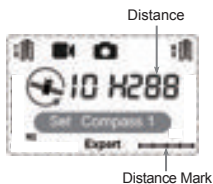

Transmitter

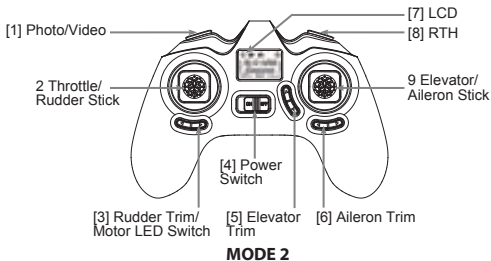
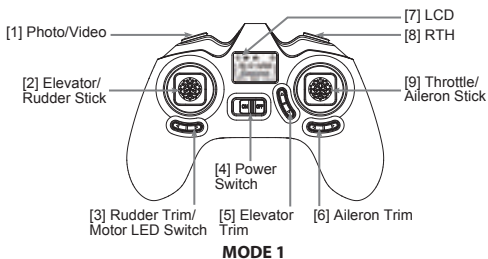

7.1 INSTALL THE TX BATTERY

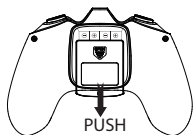

Remove the cover

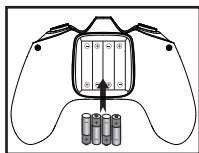

Install 4 x AAA batteries
according to the correct polarities

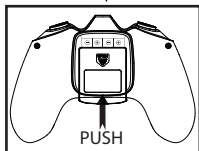

Close the cover



- Do not mix old and new batteries
- Do not mix different types of batteries
- Do not charge non-rechargeable battery.

7.2 NORMAL AND EXPERT FLIGHT MODES

The default setting for X4 is Normal Mode, and the Expert Mode can be activated to have a better sensitivity on the performance of the X4.

Press the Elevator stick 0.5 second to shift between Normal Mode and Expert Mode, indicated by one “beep”. When it enters into Expert Mode, “Expert” will be displayed on LCD.

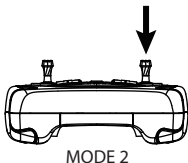

MODE 2

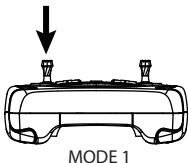

MODE 1



Normal Mode



Expert Mode

8. QUADCOPTER CALIBRATION

8.1 COMPASS CALIBRATION

Compass calibration is required when the X4 is yaw during flight, please follow the calibrating procedures:

- 1) Push the left stick to the most left side, and move the right stick left to right quickly until the transmitter displays "Set Compass 1"
- 2) Rotate the X4 horizontally clock-wise until the LCD screen displays " Set Compass 2"
- 3) Put the X4 nose down and rotate it vertically clock-wise until the " Set Compass 2" on screen disappears, and 4 LED indicators remain lighted.
- 4) Calibration done.

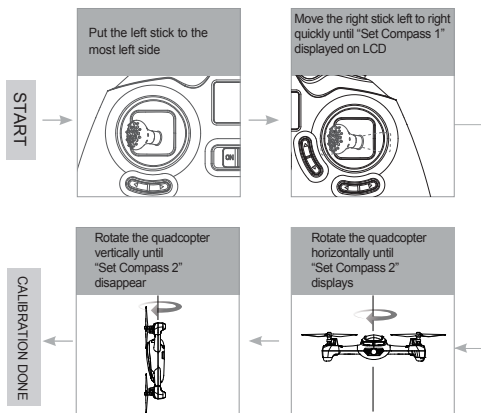

- ⊘ • Do not calibrate the compass in a strong magnetic field
- Do not carry ferromagnetic materials with you while calibrating the compass, such as keys, cell phones, etc.

8.2 HORIZONTAL CALIBRATION

Horizontal calibration is required when the X4 is drift during flight.

- 1) Push the left stick to the most right side, and move the right stick left to right quickly until the 4 LED indicators blink slowly simultaneously
- 2) Calibration succeeded when the 4 LED indicators stop blinking and remain lighted.

⚠ Flying in the area nearby magnetic field would interfere the compass which need re-calibration as above instructed.

9. TRANSMITTER CALIBRATION

Mode 2: Push both sticks to the upper left corner and power on the transmitter simultaneously. The LCD will display “H”, rotate both sticks in circles for three times, then release both sticks, press any trim for 1.5 seconds until one “Beep” heard which indicates a successful calibration.

Mode 1: Push the left stick to the upper left corner and right stick to the upper right corner and power on the transmitter simultaneously, The LCD will display “H”, rotate both sticks in circles for three times, then release both sticks, press any trim for 1.5 seconds until one “Beep” heard which indicates a successful calibration.

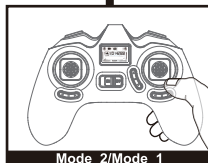
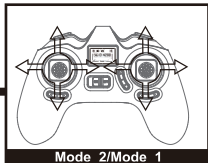
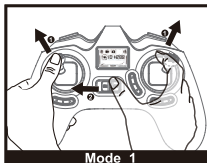
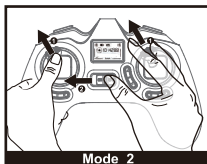

The transmitter mode can be shifted according to the above operation.

NO.	PART NAME	QTY
01	Lower Body Shell	1
02	2.4 GHz Transmission Module	1
03	Main Control Board	1
04	Compass Module	1
05	GPS Module	1
06	Blue LED	2
07	Red LED	2
08	Camera Module	1
09	Motor A	2
10	Motor B	2
11	Li-Po Battery	1
12	Screw PB1.4*3	4
13	2.4G Antenna	1
14	Upper Body Shell	1
15	GPS Shielding Case	1
16	Battery Cover	1
17	Lens Holder	1
18	Eye Lampshade	1
19	Rubber Feet	4
20	Propeller A	2
21	Propeller B	2
22	Signal Isolation Membrane	1

NO.	PART NAME	QTY
23	Battery Compartment	1
24	Motor Holder	4
25	Rotary Gear	4
26	Motor Gear	4
27	Motor Shaft A	2
28	Bearing	8
29	Screw PA1.4*7	12
30	Screw PA1.4*5	12
31	Screw PM1.4*5	2
32	Screw PA1.4*4	2
33	Motor Shaft B	2
34	Screw PM1.4*5	2

H502E SPARE PART CHART



H502E-01
Body Shell Set



H502-01
Battery Cover



H502-02
Eye Lampshade

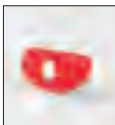

H502E-02
Lens Holder



H502-03
Lamp Base A/B



H502-04
Screw Set



H502E-03
Propeller A/B



H502-05
Motor A



H502-06
Motor B



H502-07
Motor Holder



H502-08
Shaft Sleeve



H502-20
Protection Cover

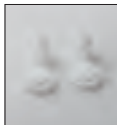

H502-10
Motor Gear B



H502-11
Motor Shaft



H502-12
LED Kit



H502-13
2.4G RX



H502E-06
Camera Module
720P



H502-14
GPS Module



H501S-13
Compass Module



H502-16
Battery



H502E-7
TX



H502-18
USB Charger



H502-19
Screwdriver



H502E-05
Crash Pack



H502-21
Battery Pack

DISCLAIMER & WARNING

Please read this disclaimer carefully before using the X4. The X4 is not suitable for people under age of 14. By using the X4, you hereby agree to this disclaimer and signify that you have read it fully. You agree that you are responsible for your own conduct and content while using the X4, and for any consequence thereof. You agree to use the X4 only for purposes that are proper and in accordance with local regulations, terms and any applicable polices and guidelines Hubsan may make available.

1. Any part of this disclaimer is subject to change without prior notice, refer to www.hubsan.com for the latest version.
2. Hubsan reserves the right of final interpretation of this disclaimer.

INSTRUCTIONS

Please read the international and domestic airspace regulations and rules before using this products, should never use the X4 in a way that infringes upon or contravenes international or domestic laws and regulations. You agree that you are solely responsible for your own conduct and content while using the X4, and for any direct or indirect consequences caused by not following this manual, violate or disregard any other applicable local laws, administrative rules and social habits thereof.

The X4 is a flying camera that offers easy flight both indoors and outdoors when powered normally and in a good working order.

1. The X4 works most efficiently with genuine Hubsan accessories , Hubsan shall not be liable for any damage or legal responsibilities to the X4 and / or accidents resulting from malfunctions of non Hubsan accessories.
2. The X4 features a built-in autopilot system and we have made its operation as safe as possible. However, it is good practice to remove all propellers before switching it on to for calibration and parameter setting.
3. Be sure to check all connections and keep children and animals a

safer distance away during firmware upgrades, system calibration and parameter setting.

CAUTIONS

Carry out each of the following steps carefully before every flight.

1. Fly safe. Stay away from obstacles, crowds, high-voltage lines and other possible sources of electromagnetic interference.
2. Check that you aren't overloading the X4.
3. Check that the propellers and the motors are installed properly and firmly before each flight. Check that the rotation direction of each propellers is correct. Do not get close to or touch working motors or propellers to avoid serious injury.
4. Avoid interference between the remote control transmitter and other wireless equipment.
5. Check that camera battery, X4 battery, transmitter battery and parachute battery are full.
6. Switch on transmitter first, then power on the X4. Upon landing, power off the X4 Pro first, then switch off the transmitter.
7. Check that all parts are in good condition. Do not fly with aging or damaged parts.
8. Do not fly near areas with magnetic or radio interference. These include but are not limited to: high voltage lines, large scale power transmission stations, mobile base and broadcasting towers. Failing to do so may compromise the transmission quality of the X4, cause remote control and video transmission errors and may effect flight orientation and location accuracy.
9. Do not use in severe weather condition including rain, snow, heavy wind, hail, lightning , tornado or hurricane.
10. Read the familiarize yourself with the quick start guide and the detailed user guide, as well as information available on the package and www.hubsan.com regularly.

THE FLIGHT ENVIRONMENT FOR X4

1. Fly the X4 in a large open area. The GPS signal may become weaker and the position hold and RTH function may not be reliable when the X4 is flown around trees and buildings.
2. Do not fly the X4 in bad weather such as, strong wind, heavy snow, rain and foggy conditions.
3. When flying the X4, please keep away from the private property of others, people, high-line cables, trees, streets and highways.
4. Do not fly the X4 near places such as airports.
5. The compass and GPS is not reliable for flights in the south and north pole.
6. Do not fly the X4 in any forbidden areas based on your country's laws and regulations.

CAMERA CARE AND USE

1. Do not allow the camera to come into contact with, or become immersed in, water or other liquids. If it gets wet, wipe dry with a soft, absorbent cloth. Turning on an the X4 that has fallen into water may cause permanent component damage.
2. Do not use substance containing alcohol, benzene, thinners or other flammable substances to clean or maintain the camera.
3. Do not store the camera in humid or dusty areas.
4. Avoid using, placing or storing the camera in the places subject to strong sunlight or high temperatures.
5. Stop operating the camera immediately if it emits smoke or noxious fumes.

6. Shoot trial images to check that the camera is operating correctly before shooting important pictures.

7. Respect the privacy of others when using the camera. Make sure you comply with local privacy laws, regulations and moral standards.

USING LITHIUM POLYMER (LIPO) BATTERIES

Li-Po intelligent battery can be extremely hazardous and require special attention when handled. Always follow the following instructions when using Li-Po battery.

1. Hubsan intelligent battery batteries must be charged with a Hubsan charger.

2. Hubsan intelligent battery is designed to stop charging when it is full. However it is good practice to monitor charging progress and disconnect the battery when fully charged.

3. Do not charge intelligent battery near flammable materials or on a flammable surfaces such as carpet or wood.

4. Never charge a swollen, leaky or damaged battery.

5. Examine charger regularly for damage to the cord, plug , enclosure or other parts. Never use a damaged charger.

6. Disconnect charger when not in use.

7. Do not clean the charger with denatured alcohol or other flammable solvents.

USAGE AND STORAGE

Keep batteries out of the reach of children and pets.

Never discharge batteries below 3V per cell.

Do not heat battery.

Do not insert or remove batteries if the plastic cover had been torn or

compromised in any way.

Do not drop or strike batteries.

Never use a swollen, leaky or damaged battery.

Clean battery terminals with a dry and clean cloth.

Do not expose batteries to extreme temperatures including excessive heat. Do not leave the batteries inside of the vehicle on hot days.

Do not allow batteries (Range extender, intelligent or remote controller) to come into contact with any kind of liquid. Do not leave batteries out in the rain or near a source of moisture.

Do not leave batteries in a microwave oven or in a pressurized container.

Do not attempt to dismantle, pierce or cut a battery. Do not attempt to repair batteries yourself.

Do not place loose battery cells on any conductive surface, such as metal-topped table.

Do not put the loose cells in pocket, bag or drawer where they may short-circuit against other items or where battery terminals could be pressed against each other.

Do not place or use batteries on strong electrostatic surfaces or surrounding areas.

This may result in battery damage.

Do not place heavy objects on batteries or charger. Avoid dropping batteries.

Avoid direct contact with the electrolyte contained within the batteries. The electrolyte and electrolysis vapors are harmful to your health.

Do not mix battery brands inside the controller.

Do not attached the battery to the wall or car charger sockets directly, always use a Hubsan approved adapter.

Remove batteries from the X4 when stored for an extended period.

BATTERY DISPOSAL

Discarding batteries in general household waste is bad for the environment. Please dispose of batteries properly.

Do not dispose of batteries in fire.

Damaged or unusable batteries must be disposed of in a container specially reserved for this purpose.

When disposing of batteries, follow appropriate local guideline and regulations. For further information contact your local solid waste authority or your battery store.

Only use the Hubsan intelligent battery.

Always use the Hubsan intelligent battery charger.

LIMITATION OF LIABILITY

Hubsan accepts no liability for damages, injuries or any legal responsibilities incurred directly or indirectly from the use of the X4 in the following conditions:

1. Damages, injuries or any legal responsibilities incurred when users are drunk, taking drugs, under the influence of anesthesia, dizziness, fatigue, nausea and other conditions both physical and mental that could impair your ability.
2. Damages, injuries or any legal responsibilities caused by subjective intentional operations.
3. Any mental damage compensation caused by accident.
4. Damages, injuries or any legal responsibilities caused by operation in no-fly zones such as natural reserve.
5. Failure to follow the guidance of the manual in assembly or operation.
6. Malfunctions caused by refit or replacement with non-Hubsan accessories and parts.

-
7. Damages, injuries or any legal responsibilities caused by using third party products or fake Hubsan products.
 8. Damages, injuries or any legal responsibilities caused by improper operation or subjective misjudgment.
 9. Damages, injuries or any legal responsibilities caused by mechanical failures due to product aging.
 10. Damages, injuries or any legal responsibilities caused by continued flying after low voltage protection alarms is triggered.
 11. Damages, injuries or any legal responsibilities caused by knowingly flying the X4 in abnormal conditions (such as when water, oil, soil, sand or other unknown material are inside the X4, incomplete assembly, the main components have obvious faults, obvious defect or missing accessories).
 12. Damages, injuries or any legal responsibilities caused by flying in the following situations such as the X4 in magnetic interference areas (such as high voltage lines, power stations, broadcasting towers and mobile base stations), radio interference areas, government regulated no-fly zones, if the pilot loses sight of the X4, suffer from poor eyesight or are otherwise not suitable for the X4 operation.
 13. Damages, injuries or any legal responsibilities caused by use in bad weather, such as a rain, heavy wind, snow, hail, lightning, tornadoes and hurricanes.
 14. Damages, injuries or any legal responsibilities caused when the X4 is in the following situations: collision, fire, explosion, floods, tsunamis, subsidence, ice trapped, avalanche, debris flow, landslide, earthquake, etc.
 15. Damages, injuries or any legal responsibilities caused by infringement such as any data, audio or video material recorded by the use of the X4.
 16. Damages, injuries or any legal responsibilities caused by the misuse of the battery, protection circuit, RC model and battery chargers.

17. Consequential damages, injuries or any legal responsibilities caused by any malfunction of an equipment or accessory, including memory cards, that results in the failure of an image or video to be recorded or to be recorded in a way that machine readable.

18. Any consequential damages, injuries or any legal responsibilities caused by operations that do not follow all instructions laid out in the quick start guide and detailed user guide or information included on the package or www.hubsan.com.

19. Operators disobey local laws or regulations.

20. Any legal responsibilities, personal or property damage or environmental damages caused by operator noncompliance with local laws and regulations.

21. Damages, injuries or any legal responsibilities caused by risky operator behavior without sufficient training.

22. Damages, injuries or any legal responsibilities caused by flying in the areas prohibited by laws, regulations, or related entities.

23. Damages, injuries or any legal responsibilities caused by operating without following instructions or warnings found on www.hubsan.com, product instructions, product quick start guideline, or Hubsan disclaimer.

24. Other losses that not covered by the scope of Hubsan innovations liability.

WARNING

1. This equipment complies with FCC RF radiation exposure limits set forth for an uncontrolled environment. The X4 complies with Part 15 of the FCC rules. Operation is subject to the following two conditions: (1) this device may not cause harmful interference, and (2) this device must accept any interference received, including interference that may cause undesired operation.

NOTE: The manufacturer is not responsible for any radio or TV interference caused by unauthorized modifications or changes to the X4. Such modifications or changes could void the user's authority to operate the product.

NOTE: This equipment has been tested and found to comply with the limits for a Class B digital device, pursuant to Part 15 of the FCC rules. These limits are designed to provide reasonable protection against harmful interference in a residential installation. This equipment generates uses and can radiate radio frequency energy and, if not installed and used in accordance with the instructions, may cause harmful interference to radio communications. However, there is no guarantee that interference will not occur in a particular installation. If this equipment does cause harmful interference to radio or television reception, which can be determined by turning the equipment off and on, the user is encouraged to try to correct the interference by one or more of the following measures:

- Reorient or relocate the receiving antenna.
- Increase the separation between the equipment and receiver.
- Connect the equipment into an outlet on a circuit different from that to which the receiver is connected.
- Consult the dealer or an experienced radio/TV technician for help.

CAUTION: RISK OF EXLPOSION IF BATTERY IS REPLACED BY AN INNCONNECT TYPE. DISPOSE OF USED BATTERIES ACCORDING TO THE INSTRUCTION.

Hubsan hereby declares that the X4 is in compliance with the essential requirements and other relevant provision of Directive 1995/5/EC.

2. Please note that the X4 is intended for personal use and should never be used in a manner that infringes upon or contravenes international or domestic law and regulations.

You shall not use the X4 to:

a) Defame, abuse, harass, stalk, threaten or otherwise violate the legal rights(such as right of privacy and publicity) of others;

b) Photograph people on private property without their consent or photograph in areas where photography is prohibited without prior authorization.

c) Use the X4 for illegal or inappropriate purpose other than general personal use (Such as spy, military operation, unauthorized investigation and unauthorized detection);

d) Violate or disregard applicable local laws, administrative rules and social habits.

Please be advised that in certain areas, the copying of images and videos from events, performances, exhibitions, or commercial properties by means of a camera may contravene copyright or other legal rights even if the image or video was shot for personal use. In addition, remote control the X4 are banned from conducting commercial activities in certain countries and regions.

If you have any problem you cannot solve during installation, please contact Hubsan authorized dealers.

Name of the products, brand, etc. appearing in this manual are trademarks or registered trademarks of their respective owner companies. The X4 and manual are copyrighted by Hubsan with all rights reserved. No part of the X4 or manual shall be reproduced in any form without the prior written consent or authorization of Hubsan. No patent liability is assumed with respect to the use of products or information contained herein.

FCC INFORMATION

This equipment has been tested and found to comply with the limits for a Class B digital device, pursuant to Part 15 of the FCC Rules. These limits are designed to provide reasonable protection against harmful interference in a residential installation. This equipment generates, uses, and can radiate radio frequency energy and, if not installed and used in accordance with the instructions, may cause harmful interference to radio communications. However, there is no guarantee that interference will not occur in a particular installation. If this equipment does cause harmful interference to radio or television reception, which can be determined by turning the equipment off and on, the user is encouraged to try to correct the interference by one or more of the following measures:

- Reorient or relocate the receiving antenna.
- Increase the separation between the equipment and receiver.
- Connect the equipment into an outlet on a circuit different from that to which the receiver is connected.
- Consult the local dealer or an experienced radio/TV technician for help.

Changes or modifications not expressly approved by the party responsible for compliance could void the user's authority to operate the equipment.

This device complies with Part 15 of the FCC Rules. Operation is subject to the following two conditions: (1) this device may not cause harmful interference, and (2) this device must accept any interference received, including interference that may cause undesired operation.

ENVIRONMENTALLY FRIENDLY DISPOSAL

Old electrical appliances must not be disposed of together with the residual waste, but have to be disposed of separately. The disposal at the communal collecting point via private persons is for free. The owner of old appliances is responsible to bring the appliances to these collecting points or to similar collection points. With this little personal effort, you contribute to recycle valuable raw materials and the treatment of toxic substances.



Electrical and electronic equipment that are supplied with batteries (including internal batteries)

WEEE Directive & Product Disposal

At the end of its serviceable life, this product should not be treated as household or general waste. It should be handed over to the applicable collection point for the recycling of electrical and electronic equipment, or returned to the supplier for disposal.

Internal / Supplied Batteries.

This symbol on the battery indicates that the battery is to be collected separately. This battery is designed for separate collection at an appropriate collection point.



User manual is subject to change without prior notice due to unforeseen product upgrades.

Download the latest user manual from

WWW.HUBSAN.COM

VERSION 1.4 EN

